



DOUGH
DIVIDERS



B 300 GV Dough Divider

The B 300 GV is a high speed dough divider. This single pocket machine with dough friendly portioning mechanism is developed especially to be used for the production of baguettes and petit pains.





WP Haton the leading brand in dough processing since 1949

WP Haton produces the most advanced and best bread make-up machines in the world contributing to high weight accuracy, excellent structure and most friendly and careful handling of the dough without compromising on high speed, consistency and constant quality on every piece of the dough piece produced.

- Automated dough processing systems for virtually all types of bread
- Tailormade line concepts in dough processing equipment
- Unique system of modularization
- BreadLab: the experience center where bakers from all over the world can test our equipment with their own ingredients

B 300 GV Dough Divider

Highlights

- Specifically developed for baguettes lines
- Dividing of 'green' dough as well pre-fermented dough
- Suitable for high-capacity lines
- High weight accuracy
- Hinged hopper for easy cleaning
- Main piston synthetic
- Measuring pistons synthetic
- Chrome nickel alloy dividing unit



B 300 GV

The B 300 GV is a high-speed dough divider with a high weight accuracy. This single pocket machine with dough friendly portioning mechanism is developed especially to be used for the production of baguettes and petit pains. The design of the B 300 GV is robust, easy to use and maintain, with a capacity of up to 3,000 pieces per hour.

Specifications

- Single pocket machine
- Dividing unit with automatic oiling on discharge conveyor, discharge flap and measuring piston
- Pneumatic discharge flap with synthetic scraper
- Hopper stainless steel 150 litres
- Hopper and hopper base Teflon coated
- PLC with touch panel
- Oil shortage detection
- Frequency inverter on main drive for adjustable speed
- Servo weight adjustment with digital read-out
- Discharge conveyor straight 1350 mm, with motor reductor and frequency inverter



Find out more about WP Haton and our products by scanning this QR-code with your mobile phone, or visit WWW.WP-HATON.COM

Technical drawing

Image for illustration purpose only

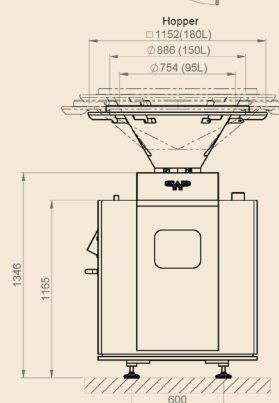
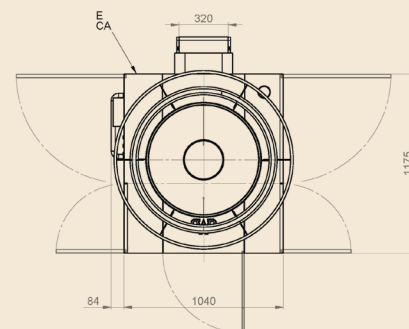
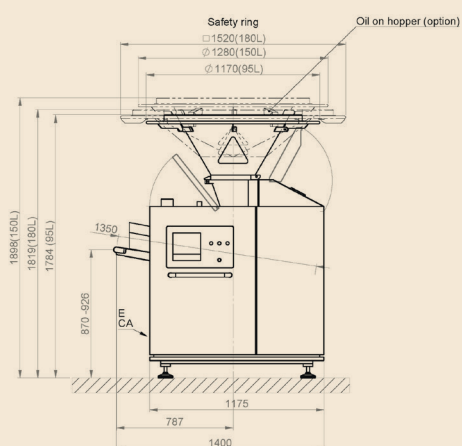
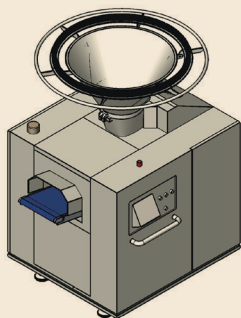

B 300 GV Measurements

TYPE	WEIGHT RANGE*	CAPACITY VARIABLE*	DIMENSIONS	
1000	100 - 1200 gr	1500 - 3000 pcs/h	Length	1420 mm
1500	200 - 1800 gr		Width	1130 mm
2000	400 - 2400 gr		Height	1860 mm

* Capacity and weight range depending on dough consistency

Options

- Oiling on hopper
- Hinged hopper stainless steel up to 250 litres, Teflon coated
- Oil tank with float-operated switch with connection to customer's central oil supply
- Customer specific Blue Box

WP HATON BV

Industrieterrein 13, 5981 NK Panningen, The Netherlands

Phone: +31 77307-1860, E-mail: info@wp-haton.com

www.wp-haton.com