



DOUGH  
DIVIDERS



# PARTAU Dough Divider

**Extremely accurate dough divider with a proven long lifetime.** This divider can be used for nearly any type of dough in almost every type of bakery.





## WP Haton the leading brand in dough processing since 1949

WP Haton produces the most advanced and best bread make-up machines in the world contributing to high weight accuracy, excellent structure and most friendly and careful handling of the dough without compromising on high speed, consistency and constant quality on every piece of the dough piece produced.

- Automated dough processing systems for virtually all types of bread
- Tailormade line concepts in dough processing equipment
- Unique system of modularization
- BreadLab: the experience center where bakers from all over the world can test our equipment with their own ingredients

# PARTAU Dough Divider

## Highlights

- Semi-industrial compact machine
- High weight accuracy
- Suitable for various dough types
- Maximum adaption to batch sizes with various hopper sizes
- Easy and quick cleaning of hopper and all parts coming in contact with dough
- Maximum adaption to individual wishes
- Low machine height with maximum accessibility



## PARTA U

The Parta U is an extremely weight accurate dough divider with a proven long lifetime. The robust design of this divider allows for nearly every dough type to be processed and at the same time a variety of dough hopper sizes enables a variation in batch size. The Parta U can be cleaned safely and easily thanks to the sideways hinged dough hopper with automated safety stop. Extremely robust design, proven quality for over 40 years.

## Specifications

- Single and multiple pocket machine
- Dividing unit with automatic oiling
- Hopper stainless steel, 120 litres, including safety ring with pressure sensitive edge
- Pistons, dividing chamber and hopper base wear-resistant Ni-Resist
- Hopper base with Teflon coating
- Knife made of hardened stainless steel
- Discharge conveyor, left or right-hand L = 725, 925 or 1275 mm



Find out more about WP Haton and our products by scanning this QR-code with your mobile phone, or visit [WWW.WP-HATON.COM](http://WWW.WP-HATON.COM)

## Technical drawing

Image for illustration purpose only

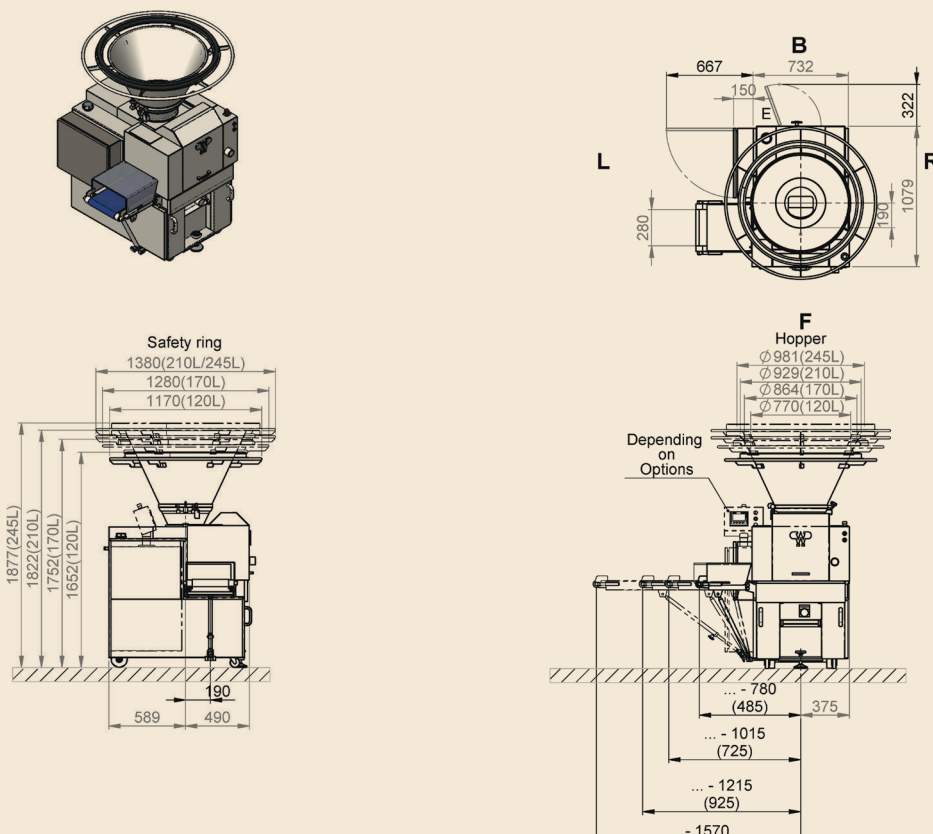

## PARTA U Measurements

TYPE	WEIGHT RANGE*	CAPACITY FIXED*	CAPACITY VARIABLE*	DIMENSIONS
2001	300 - 2800 gr	510 - 1630 pcs/h	450 - 1408 pcs/h	Length 1390 mm
2002	110 - 1250 gr	1020 - 3260 pcs/h	900 - 2816 pcs/h	Width 1080 mm
2012	300 - 2800 gr	510 - 1630 pcs/h	450 - 1408 pcs/h	Height 1620 mm
	110 - 1250 gr	1020 - 3260 pcs/h	900 - 2816 pcs/h	

\* Capacity and weight range depending on dough consistency

## Options

- Hinged hopper stainless steel 170, 210 or 245 litres, Teflon coated
- Oiling on hopper including oil shortage signalisation
- Oiling on dividing unit and internal discharge conveyor
- Drag-net on discharge conveyor
- Discharge roller with scraper (dough weights < 200 gr)
- Two mechanical flour dusters
- PLC with touch panel possibilities for: pre-set counter, recipe control, frequency inverter and/or Servo weight adjustment
- Frame increased by 100 mm
- Customer specific Blue Box

### WP HATON BV

Industrieterrein 13, 5981 NK Panningen, The Netherlands

Phone: +31 77307-1860, E-mail: [info@wp-haton.com](mailto:info@wp-haton.com)

[www.wp-haton.com](http://www.wp-haton.com)