



DOUGH
DIVIDERS



PARTAU XL Dough Divider

Extremely accurate dough divider with a proven long lifetime, with a robust design for highly automated dough processing locations. This divider can be used for nearly any type of dough.





WP Haton the leading brand in dough processing since 1949

WP Haton produces the most advanced and best bread make-up machines in the world contributing to high weight accuracy, excellent structure and most friendly and careful handling of the dough without compromising on high speed, consistency and constant quality on every piece of the dough piece produced.

- Automated dough processing systems for virtually all types of bread
- Tailormade line concepts in dough processing equipment
- Unique system of modularization
- BreadLab: the experience center where bakers from all over the world can test our equipment with their own ingredients

PARTA U XL Dough Divider

Highlights

- Three pockets for high output
- High weight accuracy
- Suitable for a wide range of dough types
- Maximum adaption to batch sizes with various hopper sizes
- Movable conveyor
- Easy cleaning and maintenance
- Low machine height with maximum accessibility



PARTA U XL

The Parta U XL is a highly accurate and user-friendly three-pocket dough divider, able to process almost all types of dough. The suction volume of the Parta U XL can be regulated for exact portioning of the dough. The relatively low working height allows for maximum accessibility, which further improves the user-friendliness.

Specifications

- Three pocket dough divider
- Dividing unit Ni-Resist with automatic oiling
- Movable discharge conveyor, cross, L = 700 / 900 / 1100 mm
- Pistons, dividing chamber and hopper base wear-resistant Ni-Resist
- Hopper base with Teflon coating
- Knife made of hardened stainless steel



Find out more about
WP Haton and our products
by scanning this QR-code
with your mobile phone, or
visit WWW.WP-HATON.COM

Technical drawing

Image for illustration purpose only

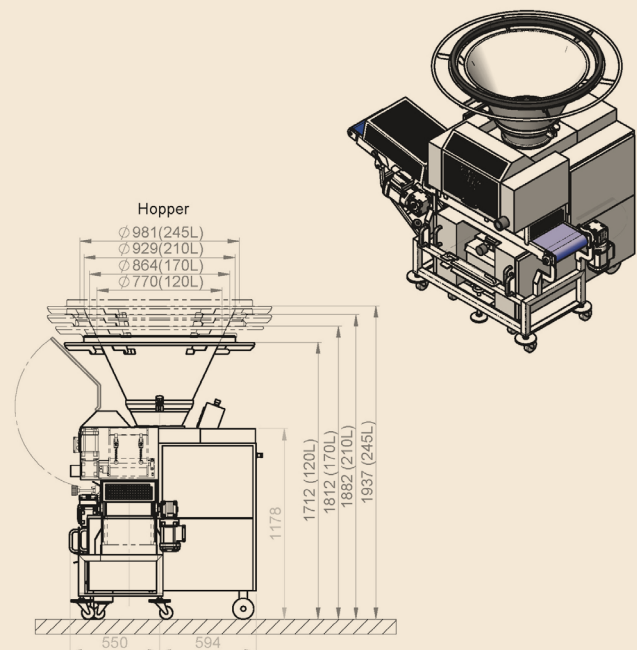
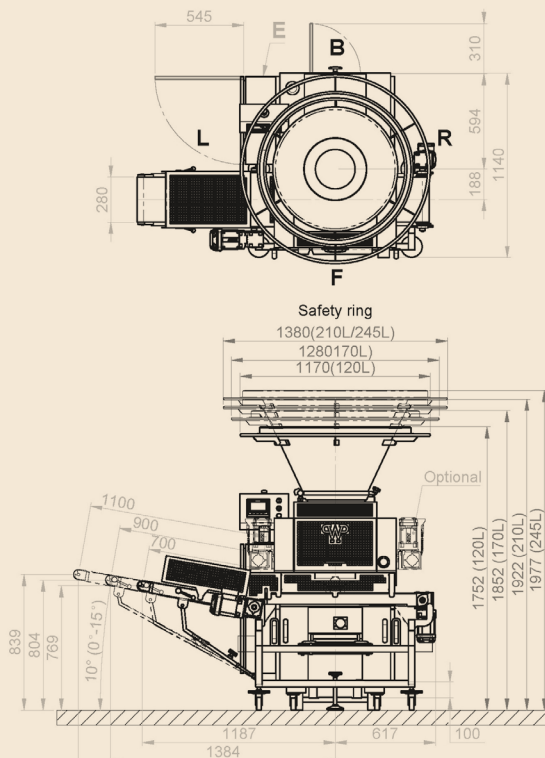

PARTA U XL Measurements

TYPE	WEIGHT RANGE*	CAPACITY FIXED*	CAPACITY VARIABLE*	DIMENSIONS
3 pockets	110 - 900 gr	1530 - 4890 pcs/h	1350 - 4224 pcs/h	Length 1390 mm
				Width 1080 mm
				Height 1620 mm

* Capacity and weight range depending on dough consistency

Options

- Hinged hopper stainless steel 170, 210 or 245 litres, Teflon coated
- Oiling on hopper including oil shortage signalisation
- PLC with touch panel possibilities for pre-set counter, servo weight adjustment and/or recipe control
- Frequency inverter for variable speed
- Drag-net on discharge conveyor
- Flour duster with separate drive
- Discharge roller with scraper (dough weights < 200 gr)
- Customer specific Blue Box

WP HATON BV

Industrieterrein 13, 5981 NK Panningen, The Netherlands

Phone: +31 77307-1860, E-mail: info@wp-haton.com

www.wp-haton.com